

<b>Description</b>	Piston-operated compact pressure regulator with special seals for applications with air, gases or liquids. Specifically designed for the chemical industry. Tamper-proof locknut supplied.
<b>Media</b>	compressed air or non-corrosive gases
<b>Supply pressure</b>	max. 21 bar
<b>Adjustment</b>	with plunger, 3 mm stroke
<b>Relieving function</b>	relieving
<b>Gauge port</b>	not available
<b>Mounting position</b>	any
<b>Temperature range</b>	0 °C to 80 °C / 32 °F to 176 °F, NBR/Buna-N 0 °C to 110 °C / 32 °F to 230 °F, FKM or EPDM for appropriately conditioned compressed air down to -30 °C / -22 °F
<b>Material</b>	Body: brass Elastomer: NBR/Buna-N, optionally FKM or EPDM Inner valve: stainless steel and brass

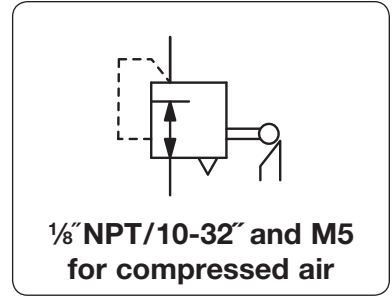

Dimensions			Description	Flow rate	Connection thread		Pressure range	Order number
A	B	A/F			Inlet	Outlet		
mm	mm	mm		l/min*1	M5 / NPT	M5 / 10-32"	bar	

Plunger operated regulator				supply pressure max. 21 bar, relieving			<b>MAR-1C</b>	
18	69	9.5	male thread	120	1/8" NPTa	10-32"	0.2...1.4	<b>MAR-1CP-20</b>
							0.2...3.5	<b>MAR-1CP-50</b>
							0.2...7.0	<b>MAR-1CP</b>
18	63	9.5	female thread	120	M5	M5	0.2...1.4	<b>MAR-1C-20</b>
							0.2...3.5	<b>MAR-1C-50</b>
							0.2...7.0	<b>MAR-1C</b>



MAR-1CP, male thread

### Special options, add the appropriate letter

for oxygen	specially cleaned	MAR-...15
FKM elastomer		MAR-...V
EPDM elastomer		MAR-...E
chemically nickel-plated	throughout	MAR-...X13



MAR-1C, female thread

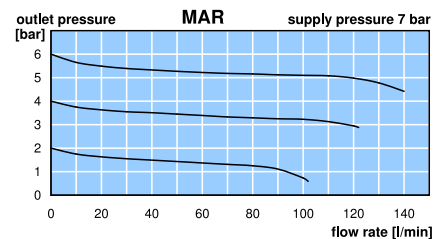
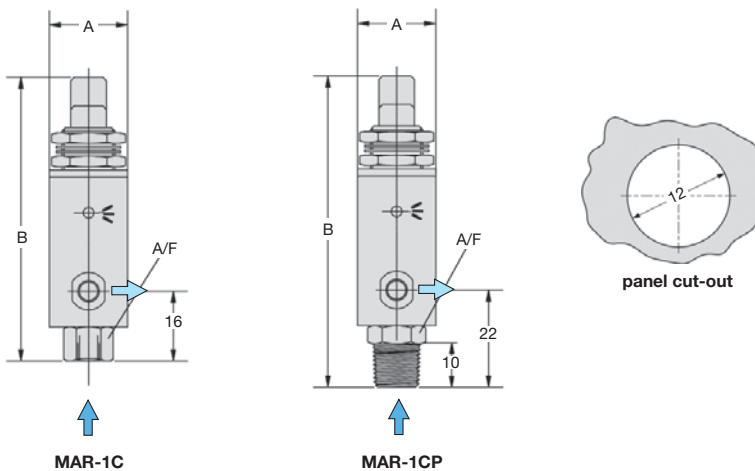

\*1 for compressed air at 7 bar supply pressure, 6 bar outlet pressure and 1 bar pressure drop

